

(No Model.)

R. H. HURLBUT.
ATTACHMENT FOR LATHES.

No. 427,869.

Patented May 13, 1890.

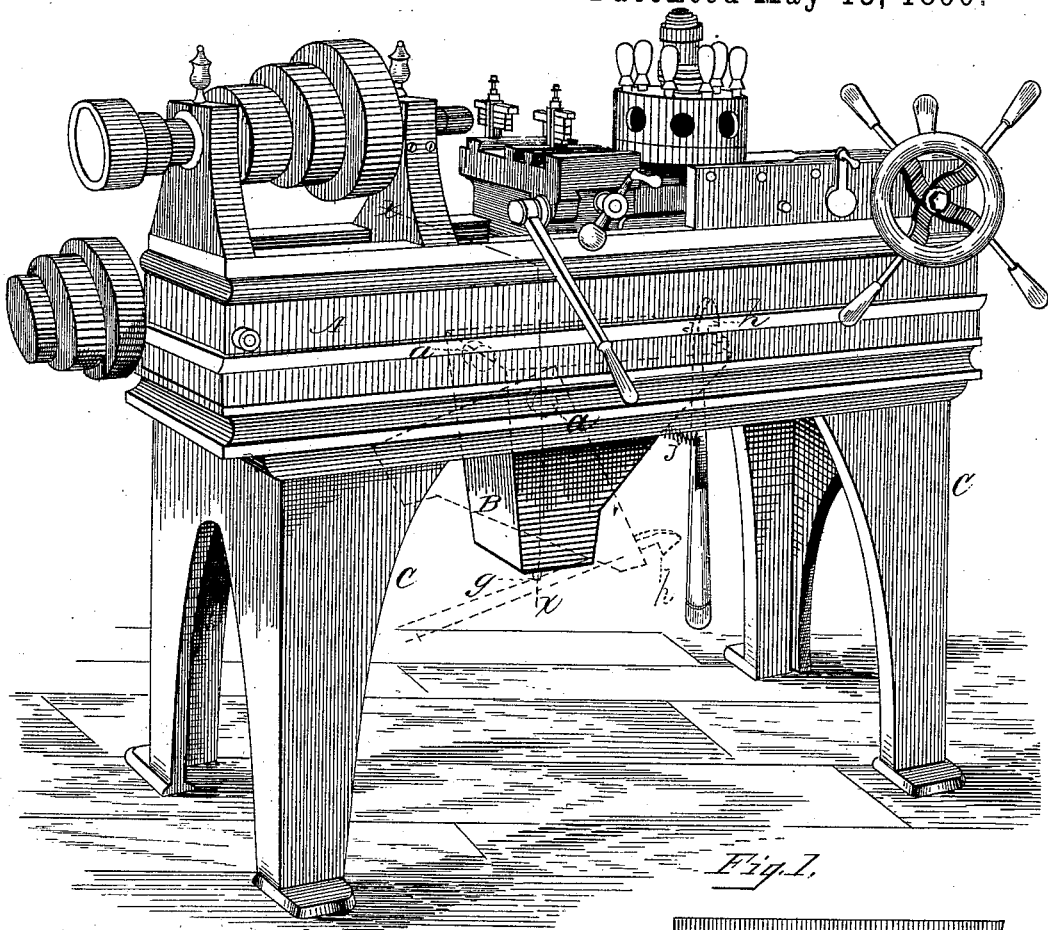

Fig. 1.

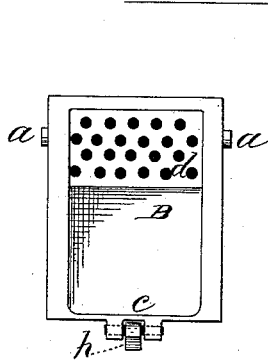

Fig. 4.

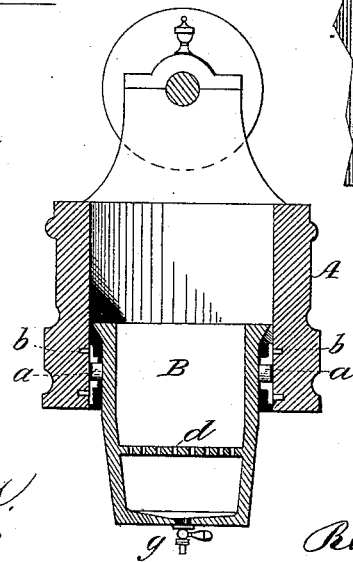

Fig. 2.

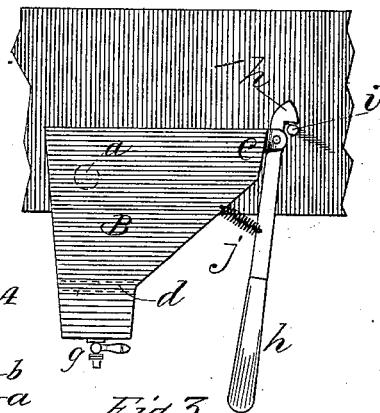

Fig. 3.

Witnesses:
James H. Williams
Geo W. Hayden

Inventor:
Rufus H. Hurlbut
by Stephen Moore
att'y.

UNITED STATES PATENT OFFICE.

RUFUS H. HURLBUT, OF SUDBURY, MASSACHUSETTS.

ATTACHMENT FOR LATHES.

SPECIFICATION forming part of Letters Patent No. 427,869, dated May 13, 1890.

Application filed January 25, 1890. Serial No. 338,128. (No model.)

To all whom it may concern:

Be it known that I, RUFUS H. HURLBUT, of Sudbury, in the county of Middlesex and State of Massachusetts, have invented a new and useful Improvement in Attachments for Lathes, of which the following, taken in connection with the accompanying drawings, is a specification.

My invention relates to receptacles for catching chips and oil from metal-working tools—such as lathes, screw-cutting machines, and the like—and has for its object the provision of such a receptacle as may separate the oil from the chips and allow the ready drawing off of the one and the dumping of the other.

It consists of a peculiarly-shaped box, usually of metal, attached to the tool carriage or frame of the machine so as to be beneath the point where the chips are formed, and so hinged that the contents can be readily dumped, and being also provided with a false bottom, which is perforated so as to allow the oil to separate from the chips and be drawn off by a cock from the space beneath the false bottom.

It consists, further, of various peculiar features set forth hereinafter, and illustrated in the drawings, of which—

Figure 1 is a perspective of the apparatus as attached to a bolt-lathe, and Fig. 2 a vertical cross-section on line *x* of Fig. 1; Fig. 3, a vertical longitudinal section of the receptacle, and Fig. 4 a plan of the same.

Similar letters of reference indicate similar parts in each.

A represents the frame of a lathe for screwing bolts, supported on suitable legs C C and provided with an iron box or receptacle B, which is pivoted to the said frame at *a* in any suitable manner. I have represented it as hung by trunnions to boxes *b b*, (see Fig. 2,) bolted to the inside of the frame A. It will be observed that the top of the box is much longer than the bottom, and that this extension is mostly at the end opposite its pivotal point, and that the slant of the said end is from a point near the bottom to a point near the top. This shape allows the contents to be readily dumped when the box is swung downward on its pivot, as shown by

dotted lines in Fig. 1. A false bottom *d* across the lower portion of the box being perforated with small holes, forms an oil-chamber, which allows the oil (frequently used with cutting-tools) to separate from the chips and collect therein, from which it may be drawn by a cock *g*.

In order to retain the box in a horizontal position, a spring-latch *h* is pivoted to the end *c* of the box and catches on a pin *i*, attached to the frame of the machine, a spring *j* serving to hold it in place. When it is desired to dump the contents of the box, the lower end of the latch *h* is moved to the right, thus releasing the top of the same from the pin *i*, when the box drops by its own gravity to the position indicated by the dotted lines in Fig. 1, thus allowing the ready removal of its contents.

In the case of lathes for turning shafting or wherever the tool-carriage is adapted to move over considerable space I attach the receptacle to the said carriage so as to move with it, and thus be always in position to catch the chips as they drop from the cutting-tool.

I claim—

1. An attachment to metal-working machines, consisting of a chip and oil receptacle hung beneath the cutting-tool of such machine by a swing-joint at one end and having a latch at the other end, adapted to hold the same in a horizontal position or allow it to be turned upon said joint so as to dump the contents, substantially as described.

2. An attachment for metal-working machines, consisting of a chip and oil receptacle pivoted to said machine at one end and having its opposite end flaring or beveled outward from near the bottom toward the top, and having said beveled end supported by a detachable latch so that the same may be dropped, when desired, to a position allowing the contents to be dumped, substantially as specified.

3. An attachment for metal-working machines, consisting of the receptacle B, pivoted at *a*, and having its opposite end *c* provided with a latch *h* adapted to catch upon a pin *i*, arranged to operate substantially as shown and described.

4. An attachment for metal-working machines, consisting of a receptacle B, pivoted at *a*, having its opposite end provided with a latch *h* to engage a pin *i* and beveled outward, substantially as herein set forth.

5. An attachment for a metal-working machine, consisting of a receptacle B, pivoted at *a*, having its opposite end *c* beveled outward and provided with a latch to retain it in a horizontal position, when desired, and a false

bottom *d* and oil-cock *g*, substantially as described.

In testimony whereof I have signed my name to this specification, in the presence of two subscribing witnesses, on this 22d day of January, A. D. 1890.

RUFUS H. HURLBUT.

Witnesses:

STEPHEN MOORE,
SAMUEL H. GREEN.